

AL 33

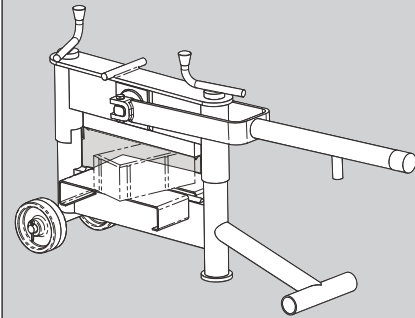

## Block Cutters AL

High stability, yet light weight, exact cutting ability.

Fast manual operation due to the favourable transmission of the eccentric lever.

- ▶ Simple and quick adjustment of the cutting height by the height adjustment screws.
- ▶ Suspended upper blade even cuts materials with a conical cross-section (such as kerb stones).

**Type AL 43/U** cuts kerb stones up to 300 mm high.

- ▶ Spring loaded suspending table ensures an exact cut.
- ▶ Both blades, top and bottom, have 4 cutting edges, thus ensuring a long life.
- ▶ The blades can be turned quickly and easily.

Type	Cutting Length mm (in)	Cutting Height mm (in)	Dead Weight kg (lbs)	Order-Number
AL 33	330 (13")	10 – 120 (1/2 – 4 3/4")	40 (88)	5120.0001
AL 43	430 (17")	10 – 120 (1/2 – 4 3/4")	60 (130)	5120.0002
AL 43/U	430 (17")	10 – 300 (1/2 – 11 3/4")	65 (145)	5120.0003
AL 65	650 (25 1/2")	10 – 120 (1/2 – 4 3/4")	80 (175)	5120.0004
AL 33/S	325 (12 3/4")	10 – 135 (1/2 – 5 3/8")	70 (155)	5120.0010
AL 43/S	430 (17")	10 – 135 (1/2 – 5 3/8")	75 (165)	5120.0011
AL 65/U	650 (25 1/2")	10 – 300 (1/2 – 11 3/4")	87 (190)	5120.0006

AL 33/S

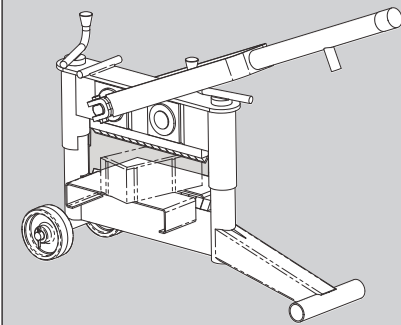

### AL 33/S and 43/S

For cutting clay pavers, natural stones and concrete pavers.

- ▶ With strengthened single spring-loaded cutting teeth which can adjust to cope with the unevenness of the blocks.

So clay pavers and natural stones also with uneven surfaces (differences up to 4 mm) can be cutted without any problems.

RSA

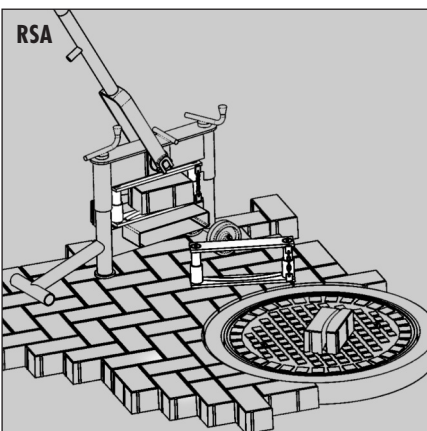

## Radial Cut Adapter RSA

The RSA converts each standard block cutter into a radial cutter within seconds.

**Simply brilliant:**

Now concrete pavers can also be cut with a radius. So connections around manhole covers can be done precisely, quickly and professionally without breaking the optics.

▶ Suitable for outside diameter of manhole covers of approx. 700 – 800 mm.

▶ Easy handling, RSA has only to be positioned between the two plates of the cutter. The RSA does not have to be rigidly fixed in this position.

Type	Cutting Length mm (in)	Required inside width of the cutter mm (in)	Cutting Height* mm (in)	Dead Weight kg (lbs)	Order-Number
RSA 25	250 (9 3/4")	355 (14")	50 – 100 (2 – 4")	4,5 (10)	4120.0016

\* Min. required distance between plates 140 mm