



PAVER TRANSPORT CART VTK-V

proven successful a 1000 times!

Even on small and middle-sized sites there are enormous cost benefits to be had in the transportation of construction materials.

With use of a wheelbarrow the transport of paver blocks would be too strenuous and too expensive.

▶ Take the advantage of a thoroughly developed technology by means of this special paver transport cart VTK-V in order to save time, manpower and costs.

▶ Easily and quickly, a complete row of pavers can be loaded mechanically and transported, either steel-strapped or stacked on pallets.

▶ Versatile use, also for the transport of kerb stones, slabs and limestones.

▶ The small design of the VTK-V (width 115 cm) has proven advantageous for narrow ways and passages.

▶ No need for a ramp!



▶ Adjustable (without the need of tools) gripping width of 550 mm to 1,050 mm. The gripping force – to the bottom of the block – is attained by a single turning of a lever.

▶ The special construction causes an optimum distribution of the load, thus saving manpower for the handling.

More „working power“
with better technology!



Paver Transport Cart VTK-V

Time and Health Saving Transport Handling

▶ In times of hard competition, permanently growing labour costs and nonwage labour costs, loss for illness and of enormous time pressure, the right working device is more than ever decisive for an economic success.

PROBST Paver Transport Cart VTK-V for an Efficient Working.



**Only 1 hour less per day means 200 hours per year!
And these are 5 weeks
of 40 hours each !!!**

Time to use the efficient PROBST equipment.

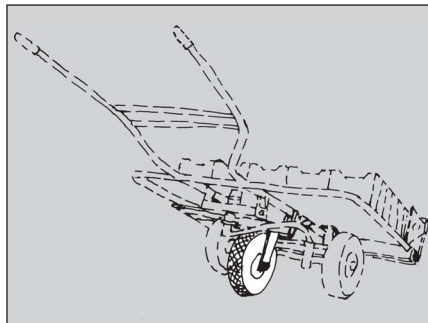

▶ A supporting wheel for easy handling on even ground is available as additional equipment.

Paver Transport Cart VTK-V

The VTK-V is a professional transport device not only for the economic transport of pavers but also for other construction materials or small construction machines.

▶ With a dead weight of only 68 kg the VTK-V shows an extraordinary high efficiency. Rows of paving blocks up to 400 kg are securely gripped and transported.

▶ Special grippers modify the minimal and maximal gripping width.

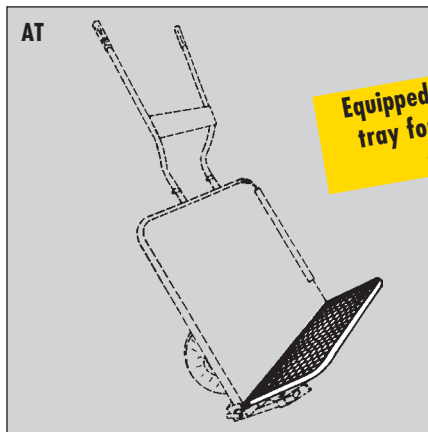
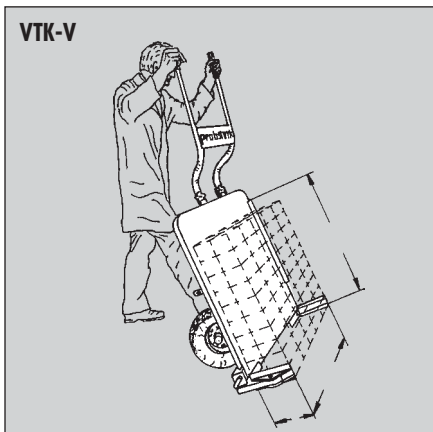

Equipped with insertable storage tray for transporting tools and small compactors!

▶ An integral protection device prevents overloading of the clamping mechanism.

▶ Durable galvanized surfaces

▶ High quality material components are the guarantee for a long operating life.

You can obtain further information and leaflets from your local Probst dealer or directly from us.

Type	Gripping Width W (mm) (in)	Block Height max. E (mm) (in)	Gripper Length L (mm) (in)	Carrying Capacity (kg) (lbs)	Dead Weight (kg) (lbs)	Order-Number
VTK-V	550 – 1,050 (21 ³ / ₄ – 41")	900 (35 ¹ / ₂ "	200 (7 ³ / ₄ "	400 (880)	68 (150)	5110.0004
VTK-V with supporting wheel	technical data see above				74 (160)	S-5110.0010
Supporting wheel, for easy handling on even ground. Can be additionally attached at any time.					7 (15)	4110.0041
Special Grippers for gripping width 830 – 1,350 mm (32 ³ / ₄ – 53")						4110.0002
Wider load support for larger spans						4110.0031
AT insertable storage tray for transporting tools, small compactors, etc.					5 (11)	4110.0010